

# 12 easy steps to safe isolation

Industrial and Commercial Installations

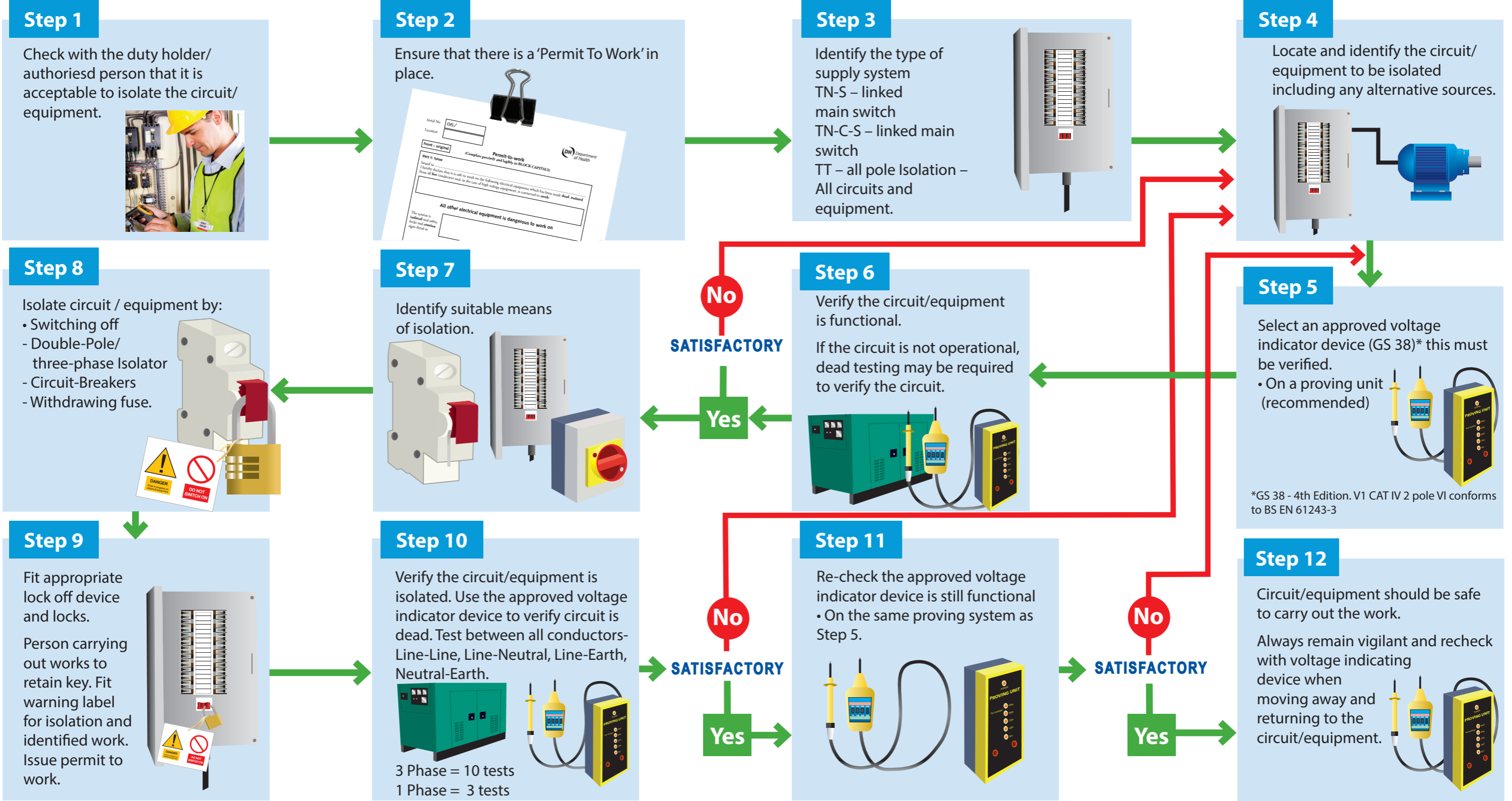

## Process for re-energising the circuit/system

